



COMMERCIAL MIXERS

GEM120 20 Quart Mixer



GEM120
20 Quart Mixer

FEATURE LIST	
Model:	GEM120
Description:	20 Quart Mixer
Voltage:	120/60/1, 220/50/1, 220/60/1
Rated Power:	1.5 hp
Bowl Capacity:	20 qt
Speed:	108/195/355 R/MIN
Weight:	227 lb

These all-purpose mixers use a planetary mixing action that consistently blends, mixes and aerates all ingredients with satisfactory results. The heat treated carbon steel gears deliver energy at three pre-selected fixed speeds. Each mixer comes standard with a stainless steel bowl, flat beater, spiral dough

hook, and wire whip. The stainless steel wire front bowl guard opens easily for adding ingredients. The bowl guard magnetic lock prevents the mixer from running if guard is opened or the bowl is lowered. The switches are moisture resistant. All units come with an overload switch which protects the motor.



Specifications subject to change without notice.

Approvals:



PLAN VIEW

GEM120

20 Quart Mixer

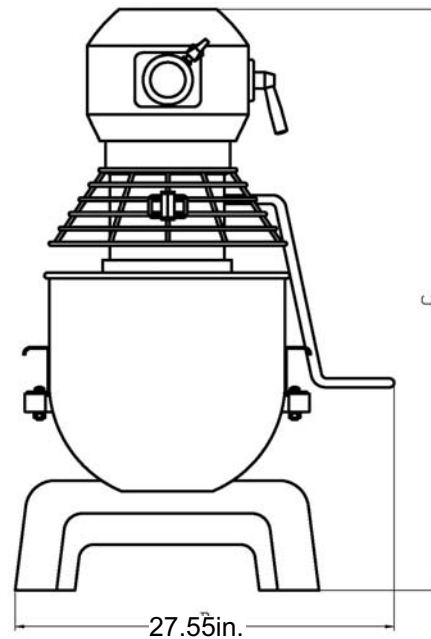
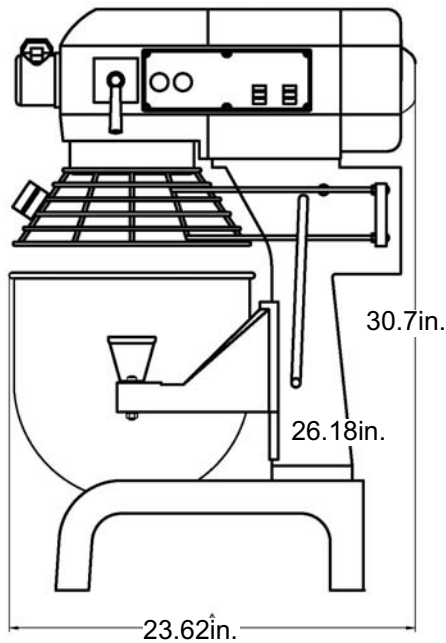

Dimensional Data

Model	Description	Voltage	Rated Power	Bowl Capacity	Speed	Weight
GEM120	20 Quart Mixer	120/60/1 220/50/1 220/60/1	1.5 hp	20 qt	108/195/355 R/MIN	227 lb

- Mixer has a 3 speed, 1.5 hp, totally enclosed and permanently lubricated, thermally protected motor. Electrical specs 120/60/1, 220/50/1, 220/60/1, 15amp. Speed 108/195/355R/min
- Heat treated carbon steel gears fully sealed allow durability and dependability with quiet operation.
- 3 Pre-selected, fixed speeds.

- Manual bowl lift is lever operated and self locking in top position.
- #12 Taper hub front port.
- Spiral Dough Hook, Flat batter beater, and wire whip.
- Bowl guard with magnetic lock prevents the unit from running if guard is open.
- Overload Switch on all mixers.
- Switches are moisture resistant.